

MW Engineering Change 4.0.0

BEHAVIOR CHANGES	2
Workflow Jumps.....	2
Group Review Sign In.....	2
Workflow Definition File and Installations.....	3
Other.....	3
ENHANCEMENTS	4
Performance Improvements.....	4
<i>Loading the Data Card</i>	4
<i>Workflow Event</i>	4
<i>1-Click Commands</i>	4
Task Manager Compatibility.....	5
<i>Tasks</i>	5
<i>Task Manager Emails</i>	6
EC Search Tool.....	7
User Interface Improvements.....	13
<i>Loading Dialogs and Workflow Events</i>	13
<i>Dynamic States</i>	13
<i>Group Review States</i>	14
<i>Create Menu Items</i>	14
Attachments.....	15
<i>New Action</i>	15
<i>Global Option</i>	16
Database Updates.....	18
<i>ABBREV_NAME field</i>	18
<i>Out of the Box User Fields</i>	18
Delete RLMD Tool.....	19
Logging Improvements.....	20
Edit Revisions Data Card.....	21
BUG FIXES	22

BEHAVIOR CHANGES

Workflow Jumps

The Workflow Designer allows jumps to multiple states:

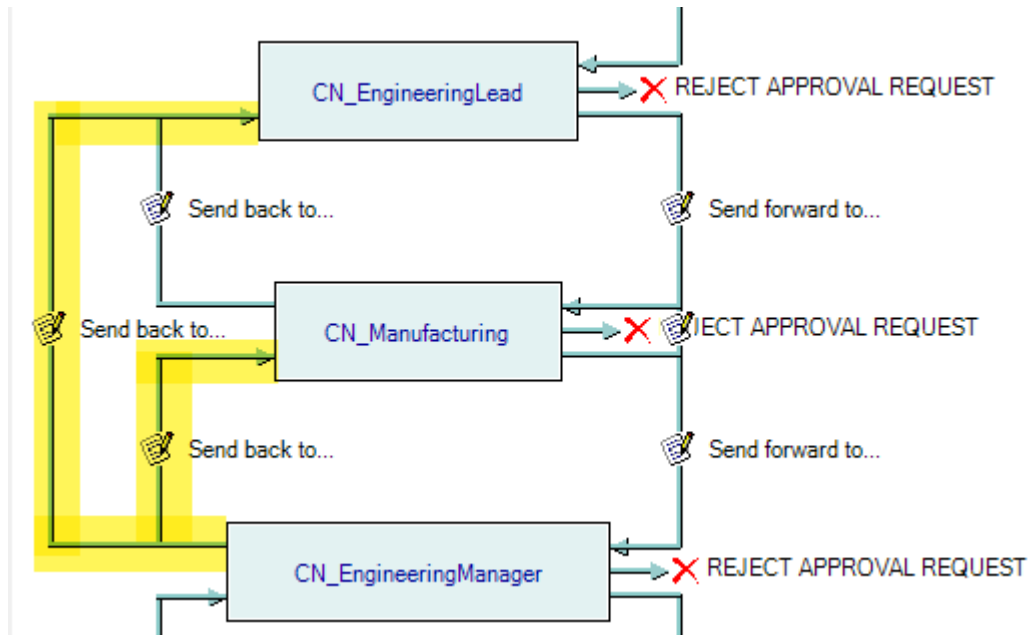

The Workflow Menus now reflect all available jumps:

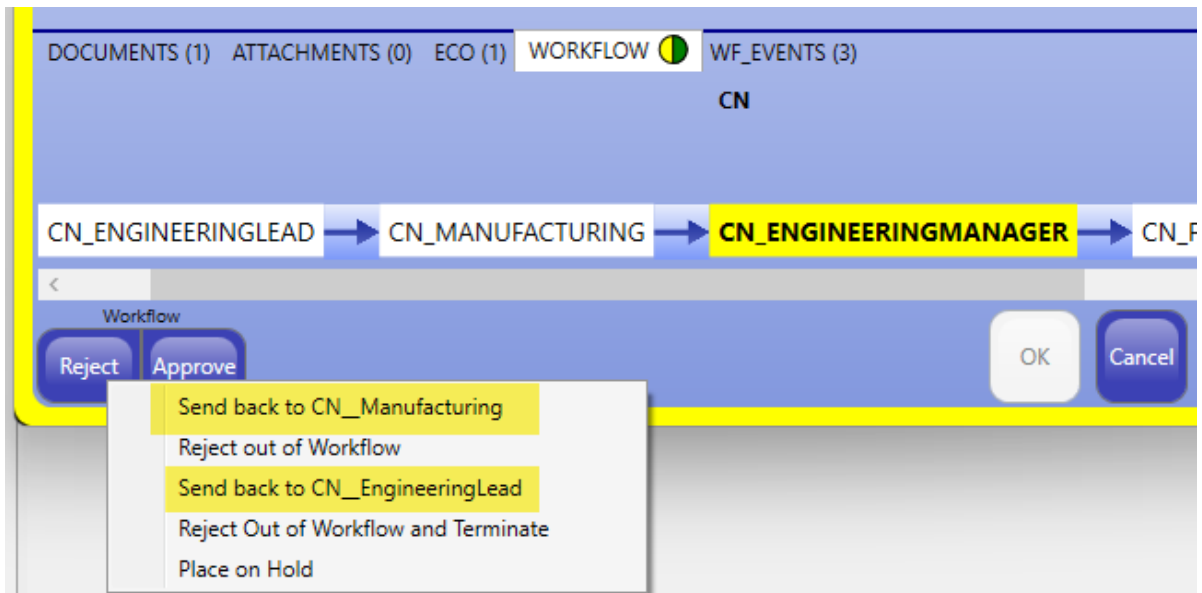

Group Sign In Tool

Previously, being logged in using the Group Review Sign-In tool was recorded in the database. Now, it is recorded only in local memory.

Workflow Definition File and Installations

When installing the MW Engineering Change tool for the very first time, users are now given the option overwrite their current workflow definition file with the default version for the MW Engineering Change tool:

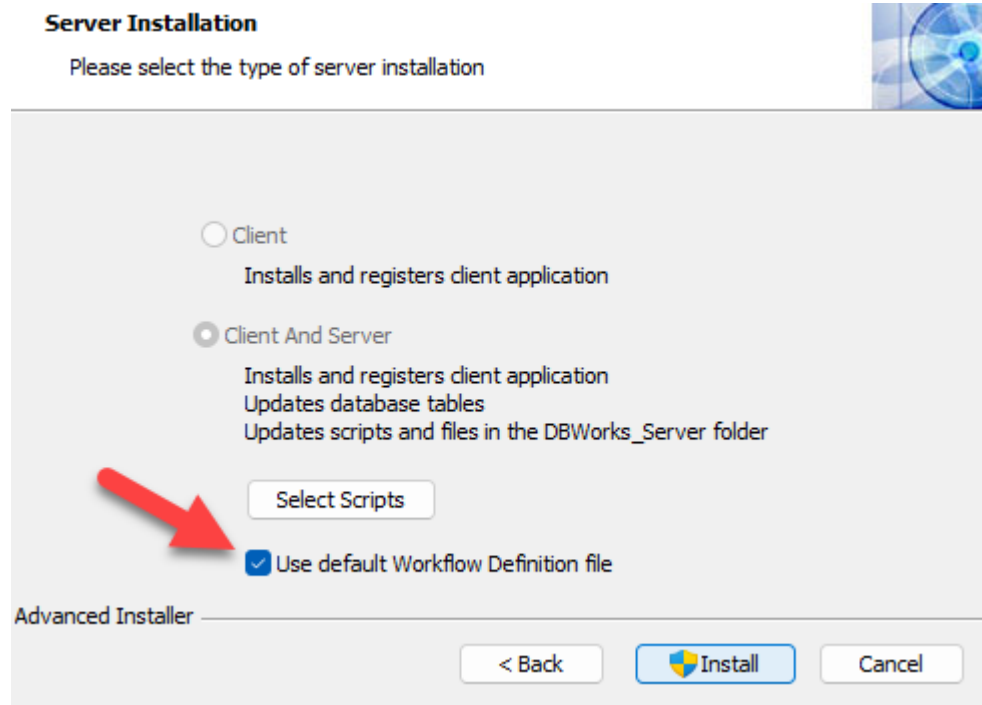

NOTE: If the workflow definition file is not overwritten, it will likely need to be modified before the MW Engineering Change tool can be used. The administrator will need to configure specific workflow processes for IRs, ECRs and ECNs.

Otherwise, the MW Engineering Change installer will only install the default workflow definition file if there is no workflow definition file stored in the schema folder.

Other

- Drop down LSTs now allow NULL values
- The EC grid (in the MechWorks PDM browser) is now automatically refreshed after creating or terminating an EC record
- Removed ASYNC functionality from all scripts to improve stability and performance
- Files are now copied into the %temp% folder before being attached to an email. This avoids permissions issues that can sometimes occur when attaching files from the network. This behavior can be disabled in the main options file.
- Attachments to the EC record are now always writable (even when copied from a read-only file). This behavior can be disabled in the main options file.

ENHANCEMENTS

Performance Improvements

Loading the Data Card

The underlying algorithm loading the Data Card has been reorganized to improve performance. Exact improvements will vary depending on several variables, but on average, Data Cards should load about 70% faster. (A Data Card that previously took about 10 seconds to load might now take about 3 seconds to load.)

Workflow Events

The underlying algorithm executing Workflow Events (submissions, rejections, and approvals) has also been reorganized to improve performance. Exact improvements will vary greatly depending on several variables (especially Actions). On average, Workflow Events are about 20% faster. (An approval that previously took about 10 seconds will now take about 8 seconds).

1-Click Commands

Previously, users needed to open the Data Card in view-only mode first, then select the [Edit] button to refresh the Data Card into edit mode. Now, users can open the Data Card directly in edit mode using the new command in the context menu:

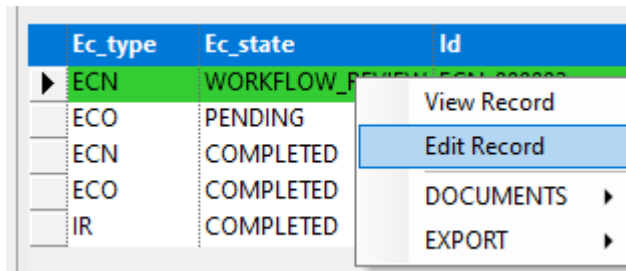

The screenshot shows a table with three columns: 'Ec_type', 'Ec_state', and 'Id'. The first row is highlighted in green and has a context menu open over it. The context menu contains the following options: 'View Record', 'Edit Record', 'DOCUMENTS', and 'EXPORT'. The 'Edit Record' option is highlighted in blue.

Ec_type	Ec_state	Id
ECN	WORKFLOW_F	ECN1234567
ECO	PENDING	
ECN	COMPLETED	
ECO	COMPLETED	
IR	COMPLETED	

Allowing users to go directly to edit mode significantly improves performance. Exact improvements will vary depending on several variables, but on average, it takes about 70% less time to open a Data Card in edit mode.

Task Manager Compatibility

Tasks

If an environment has configured MechWorks PDM for using one or more Task Manager machines, users will now be presented with the option to Execute on the Task Manager when submitting to workflow, as well as when rejecting or approving in workflow:

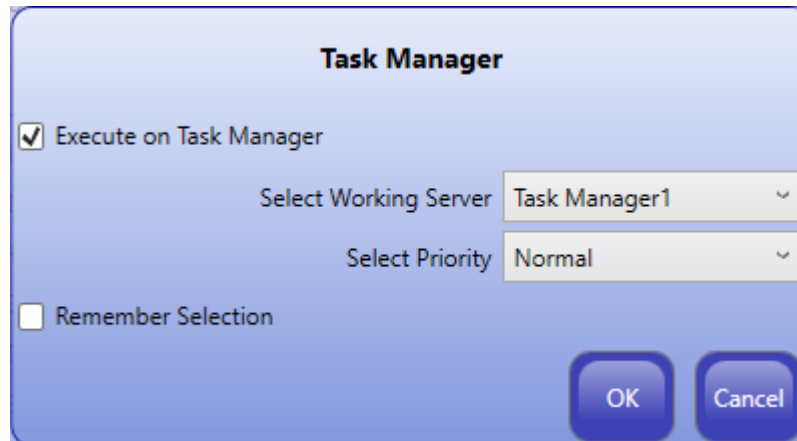

The options are described as follows:

Execute on Task Manager: Execute the submission, approval, or rejection on the Task Manager rather than the local machine.

Select Working Server: Drop down list of available Task Manager machines. NOTE: The drop down list will only display Task Manager machines using the same application as the local machine. For example, if the local machine is using DBWorks Standalone, the drop down list will only display Task Manager machines also running DBWorks Standalone.

Select Priority: Set the priority of the task. The Task Manager will prioritize High priority tasks over Normal priority, and Normal priority tasks over Low priority.

Remember Selection: If checked, the MW Engineering Change tool will remember the users selections and stop prompting the user about executing on the Task Manager. If the “Execute on Task Manager” option is selected, the MW Engineering Change tool will automatically execute all submissions, approvals, and rejections on the Task Manager selected using the priority selected. NOTE: Restarting MechWorks PDM will reset the “Remember Selection” option.

While an EC record is waiting for a task to execute on the Task Manager, its Data Card can only be opened as View Only. The “Edit” button will be disabled until the Task is completed:

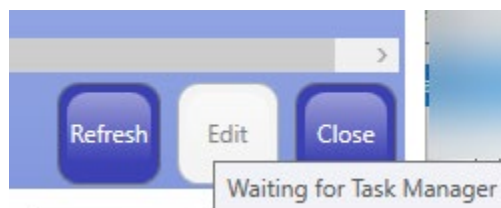

Task Manager Emails

Emails cannot be generated on the Task Manager. If a workflow event would normally generate an email, the Task Manager will instead create an entry in a special table in the database indicating that an email may still need to be generated regarding a specific user event. Users can then use the Task Manager Emails tool to automatically generate any of these emails after the workflow event has finished executing on the Task Manager:

Generate Email	Email Type	ID	Description	Primary Document	Process	From State	To State	Date	Delete Email
<input checked="" type="checkbox"/>	GENERATE EMAIL TO SUMITTING USER WHEN APPROVING OUT OF ECR WORKFLOW	ECO-00411	Fix spelling error	145G4001-4-1	ECR	FINAL	END	11/2/2022 1:51:04 PM	<input type="checkbox"/>
<input checked="" type="checkbox"/>	GENERATE EMAIL TO SUMITTING USER WHEN APPROVING OUT OF ECR WORKFLOW	ECO-00412	Change material	145G4001-4-1	ECR	FINAL	END	11/2/2022 2:02:18 PM	<input checked="" type="checkbox"/>

To generate one or more emails, check the “Generate Email” box in the grid, then select the “Generate Email” button in the lower left corner.

Emails can also be deleted without generating by checking the “Delete Email” box in the grid, then selecting the “Delete Emails” button in the lower right corner.

NOTE: The Task Manager Emails tool is user specific. It will only display emails for workflow events executed by the current user.

EC Search Tool

EC Search Tool

The main interface of the EC Search tool has been simplified and improved:

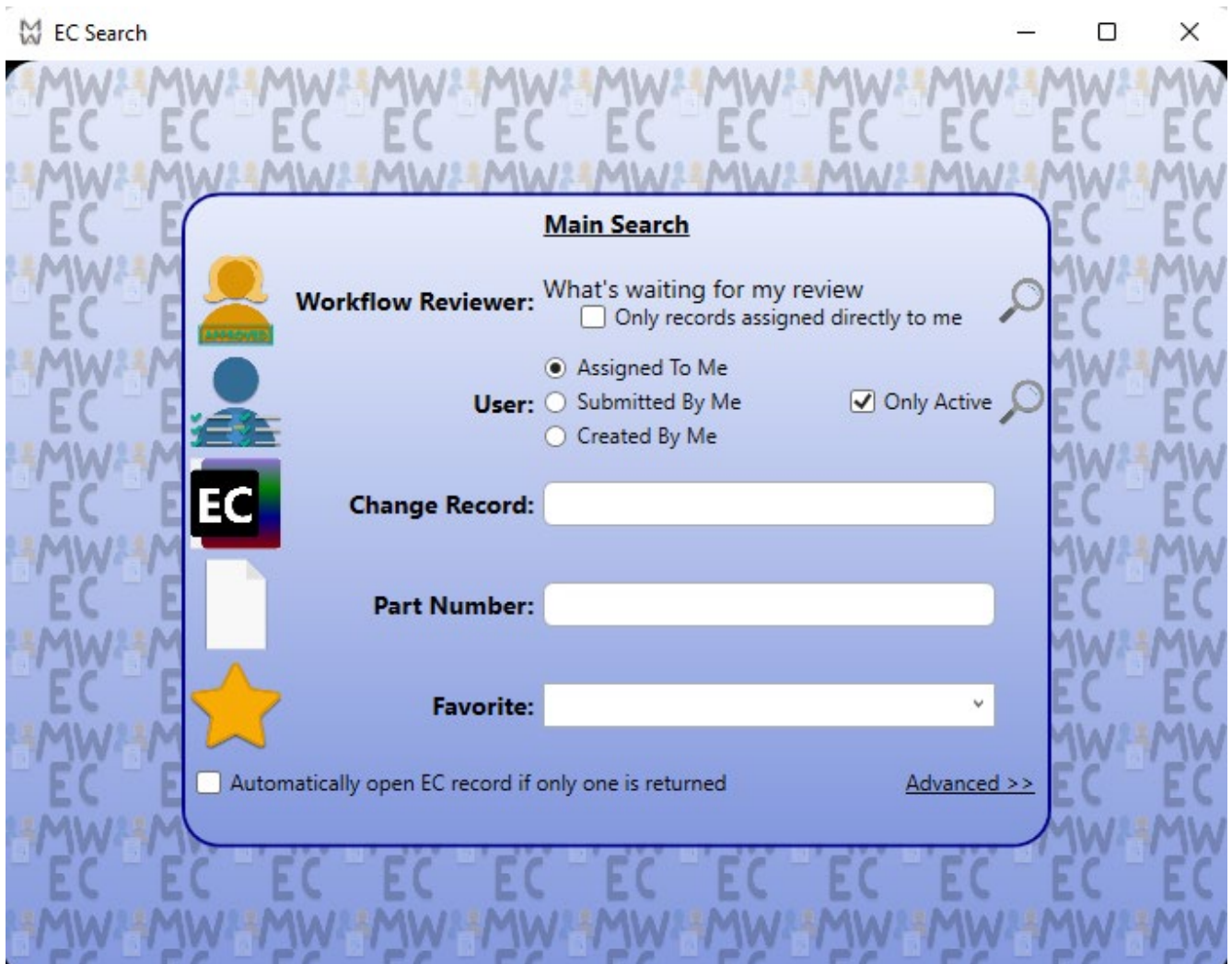

The main interface now has 5 search types:

- **Workflow Reviewer:** For users who typically reject or approve records in Workflow.
- **User:** For non-reviewers (designers, managers, manufacturers, etc).
- **Change Record:** A full-text search to allow a user to search for a specific EC record (i.e. ECN-006759)
- **Part Number:** A full-text search to allow a user to search for EC records associated with a given Part Number (i.e. D12-4523)
- **Favorite:** A drop-down list of all the saved “favorite” searches for a given environment/user.

Each search type and the various options will be reviewed on the next page.

The legacy “Advanced” search can still be accessed using the “Advanced >>” link in the bottom right corner of the dialog:

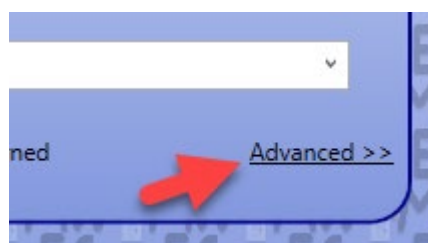

Workflow Reviewer

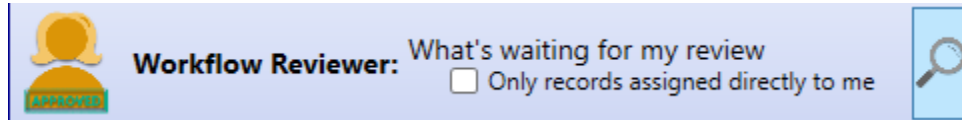

By clicking on the search icon/button on the right, the EC Search tool will return any records currently in a Workflow State that the current user is allowed to reject or approve from. For example, an environment might have a Managers group, and all users in the Managers group have the right to approve or reject from the Workflow State called “CN_Managers”. If a user in the Managers group runs this search, the EC Search tool will return all EC records currently waiting in the “CN_Managers” Workflow State.

Only records assigned directly to me

This sub-option is used in conjunction with the tool to assign an Active Reviewer in Workflow:

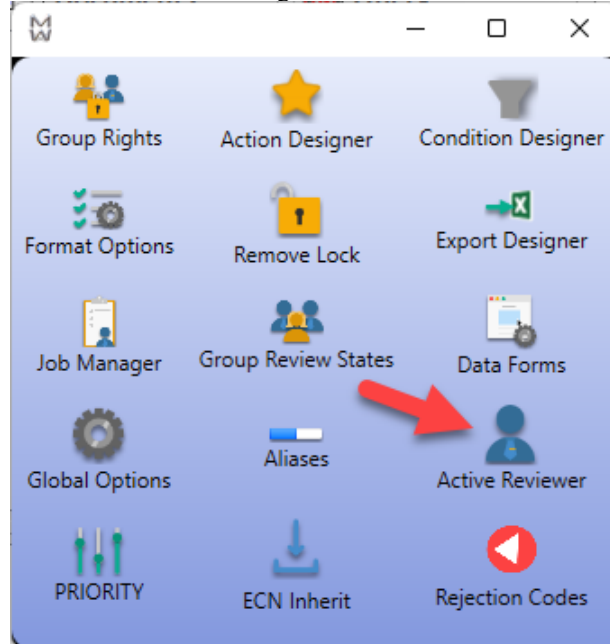

If this sub-option is checked, then the search will further filter only for EC records in which the current user is the assigned “Active Reviewer”.

User

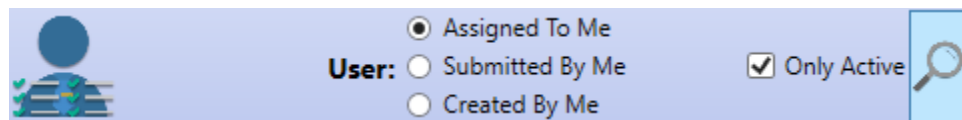

This search is designed to return EC records associated with the current user based on one of the three sub-options below:

Assigned To Me

This search will return all EC records in which the current user is assigned in the USER_ASSIGNED field. This field is typically used to assign designers and engineers to approved ECOs.

Submitted By Me

This search will return all EC records which were submitted into Workflow by the current user.

Created By Me

This search will return all EC records which were created by the current user.

Furthermore, in all three cases, checking the Only Active option will further filter the returned EC records to only include “active” records (exclude COMPLETED or TERMINATED records).

Change Record

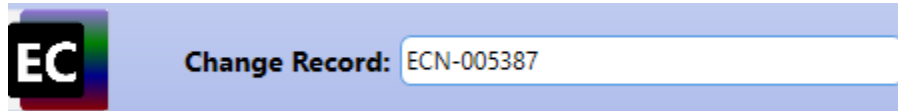

This is a full-text search allowing the user to type in the number (or partial number) of a particular EC record. Selecting “enter” will run the search.

Additionally, right mouse selecting the “Change Record” text will display a menu with the most recent 10 searches, allowing the user to quickly re-run a recent search:

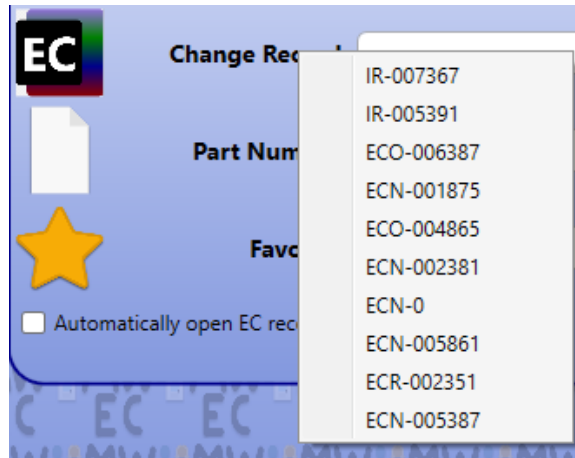

Part Number

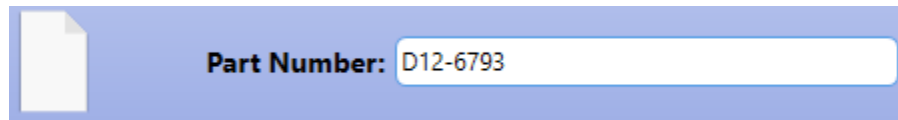

This is a full text search allowing the user to type in a part number (or partial part number) of a particular drawing or document registered in MechWorks PDM. Selecting “enter” will cause the EC Search tool to return all the EC records associated with the given part number.

Additionally, right mouse selecting the “Part Number” text will display a menu with the most recent 10 searches, allowing the user to quickly re-run a recent search:

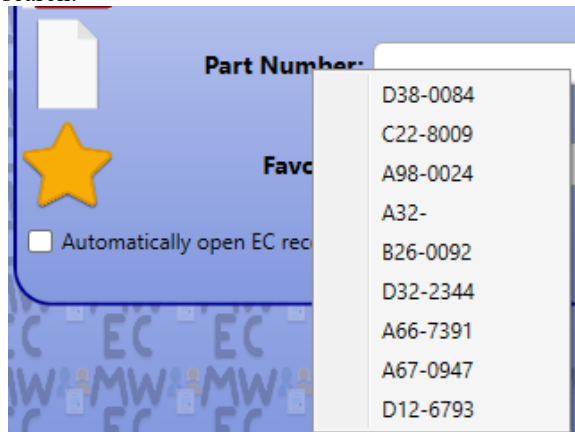

Favorite

This is a drop down menu displaying the saved “favorite” searches:

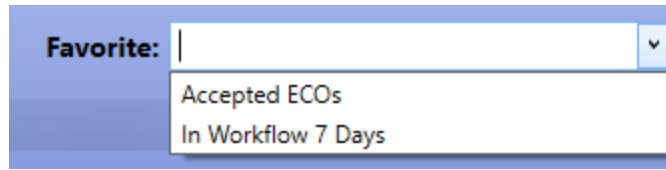

Favorite searches (global and user) can still be configured, saved and removing in the “Advanced” section of the EC Search tool:

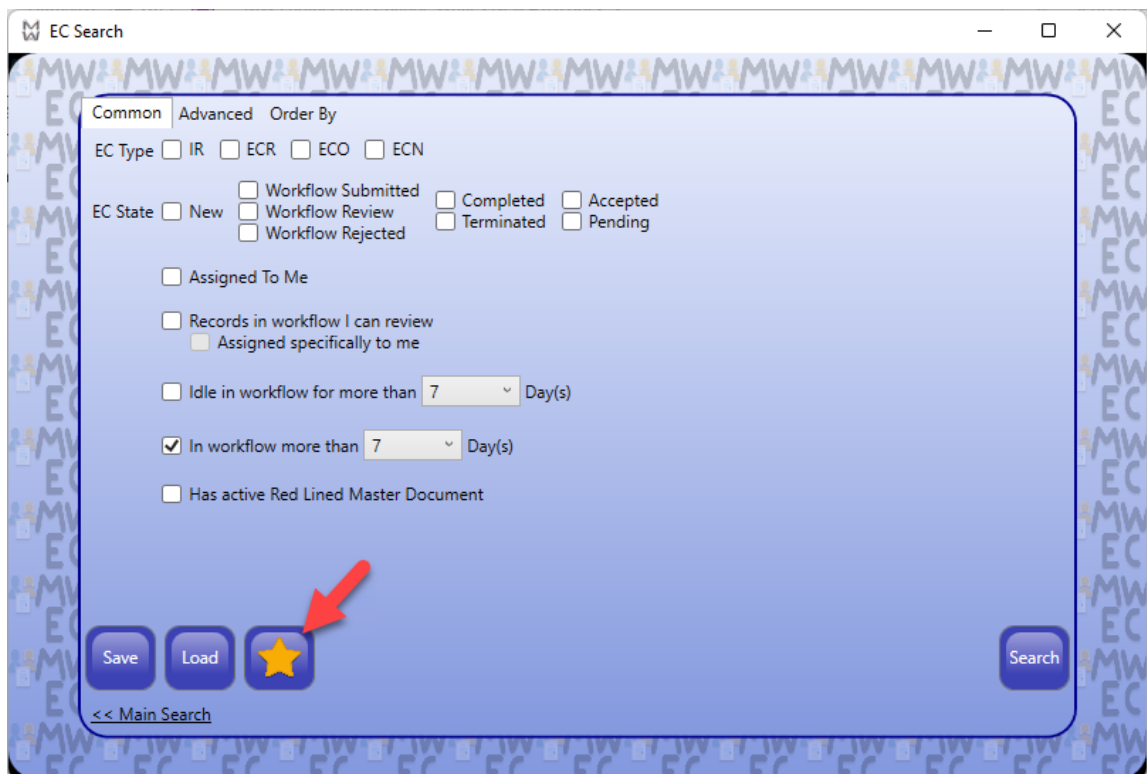
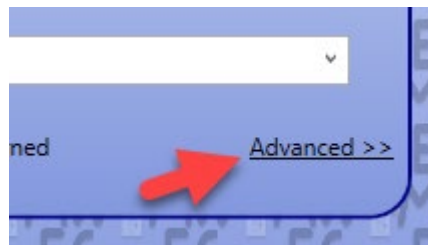

For more information about configuring, saving, or removing favorite searches, please see the “MW Engineering Change What’s New 3.0.0” documentation.

Additionally, users can start typing a favorite search into the text box to have the EC Search tool auto-fill the search:

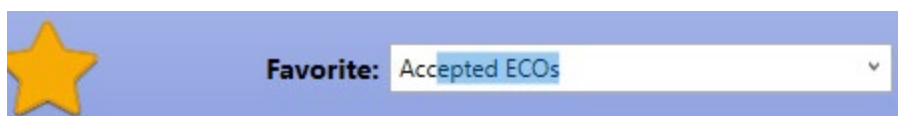

Selecting “enter” will execute the auto-filled search.

Finally, the EC Search tool has an option to Automatically open EC record if only one is returned in the lower left corner:

The image shows a screenshot of the 'Main Search' interface. On the left side, there is a vertical navigation menu with icons for 'Workflow Reviewer' (a person), 'User' (a person), 'EC' (a document with 'EC' on it), a document icon, and a star icon. The main search area contains the following elements:

- Main Search** (title)
- Workflow Reviewer:** 'What's waiting for my review' with a search icon. Below it is a checkbox for 'Only records assigned directly to me'.
- User:** Radio buttons for 'Assigned To Me', 'Submitted By Me', and 'Created By Me'. To the right is a checkbox for 'Only Active' with a search icon.
- Change Record:** A text input field.
- Part Number:** A text input field.
- Favorite:** A dropdown menu.
- At the bottom left, a checkbox labeled 'Automatically open EC record if only one is returned' is checked. A red arrow points to this checkbox.
- At the bottom right, a link labeled 'Advanced >>'.

This option can be used with any of the five search types. If selected, the EC Search tool will automatically open the Data Card of the EC record returned if only one record is returned by the search. (This option is especially useful when using the “Change Record” full text search to retrieve a specific EC record.)

Additionally, if the EC record can be opened in Edit Mode, the EC Search tool will automatically only the Data Card in Edit Mode, avoiding requiring the user to refresh from View to Edit Mode.

Search Results Page

The Search Results page of the EC Search tool has also been simplified and improved:

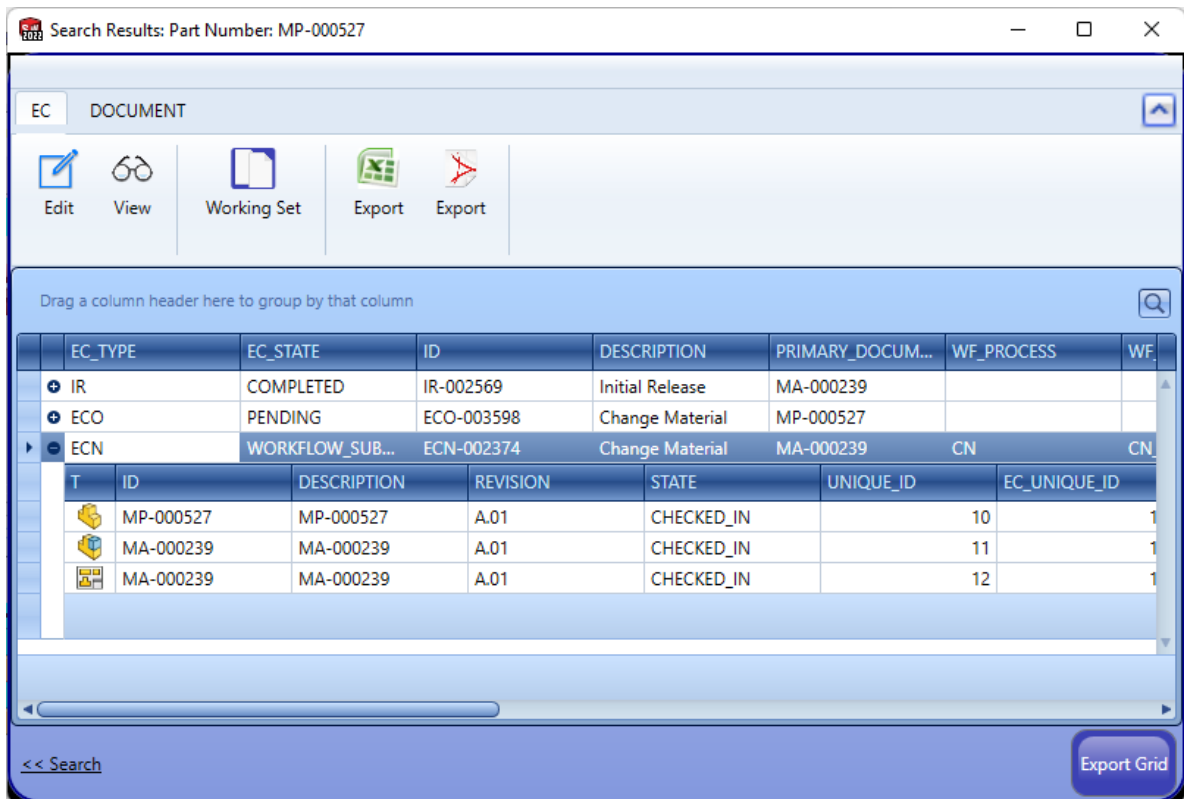

The Advanced Search has been replaced with a ribbon. The ribbon provides easy access to commands available for the selected EC record, or the selected DOCUMENT record.

Additionally, the bottom right corner of the dialog now includes an “Export Grid” button, which will allow the user to export the search results to a .csv file.

The user can return to the main search page by selecting the [<< Search](#) link in the bottom left corner of the dialog.

User Interface Improvements

Loading Dialogs and Workflow Events

When loading any dialog, the MW Engineering Change tool now provides a progress bar and updates regarding the steps to completion:

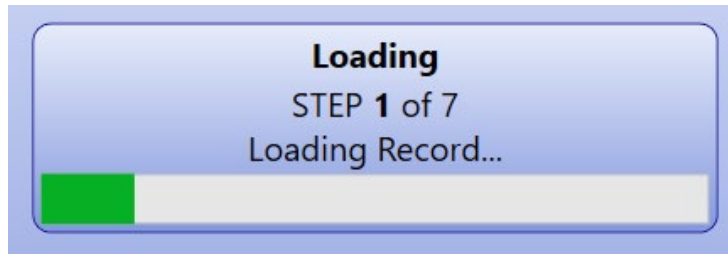

Similarly, Workflow Events provide a progress bar and updates:

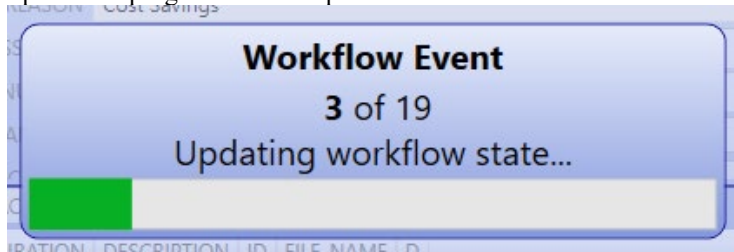

Dynamic States

Dynamic states are now more visible using stripes in the Workflow tab:

Before:

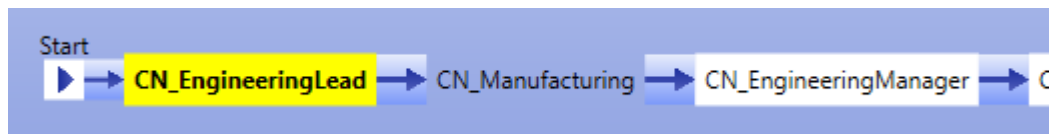

After:

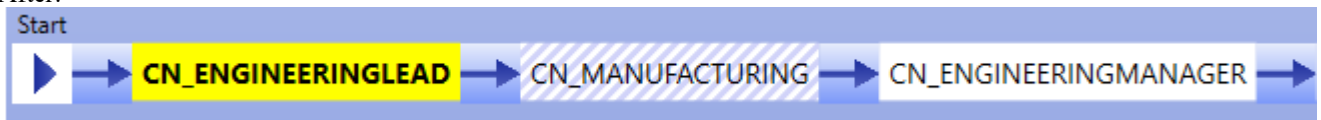

Group Review States

Group Review states are now indicated by an icon in the Workflow tab:

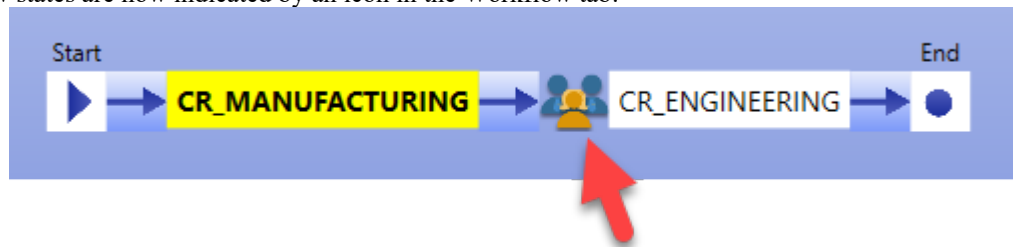

Also, viewing the decision makers of a Group Review state now displays each “Workflow Group” (and its users) by default:

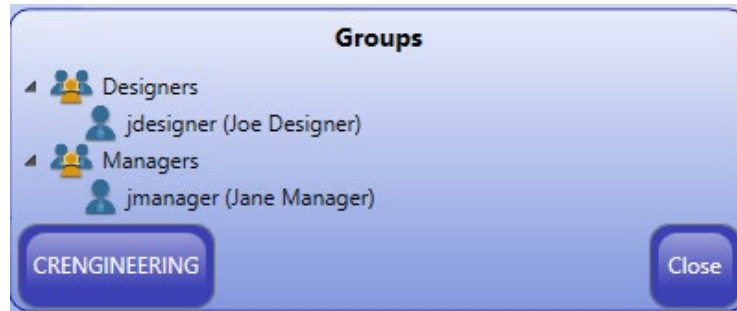

Users can view reviewers assigned directly to the Workflow State by selecting the button in the bottom right corner.

Create Menu Items

The “Create” menu items now include icons:

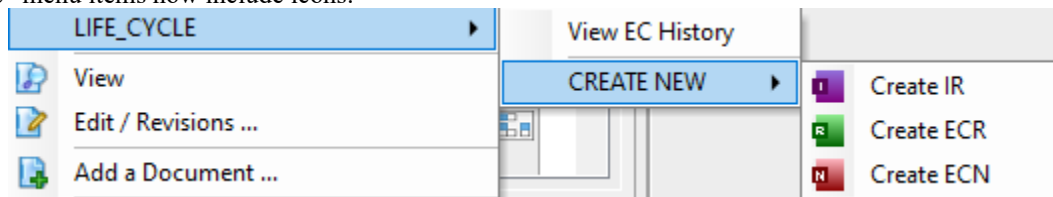

They are also now available directly in the main menu:

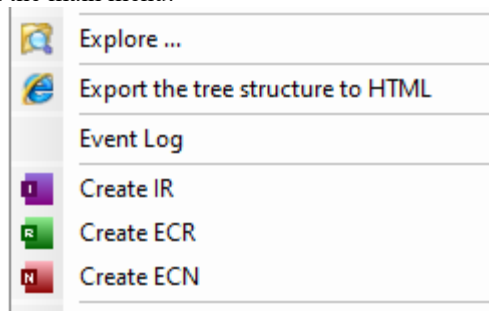

Attachments

New Action

Administrators can now create an action to automatically create an attachment for the EC record:

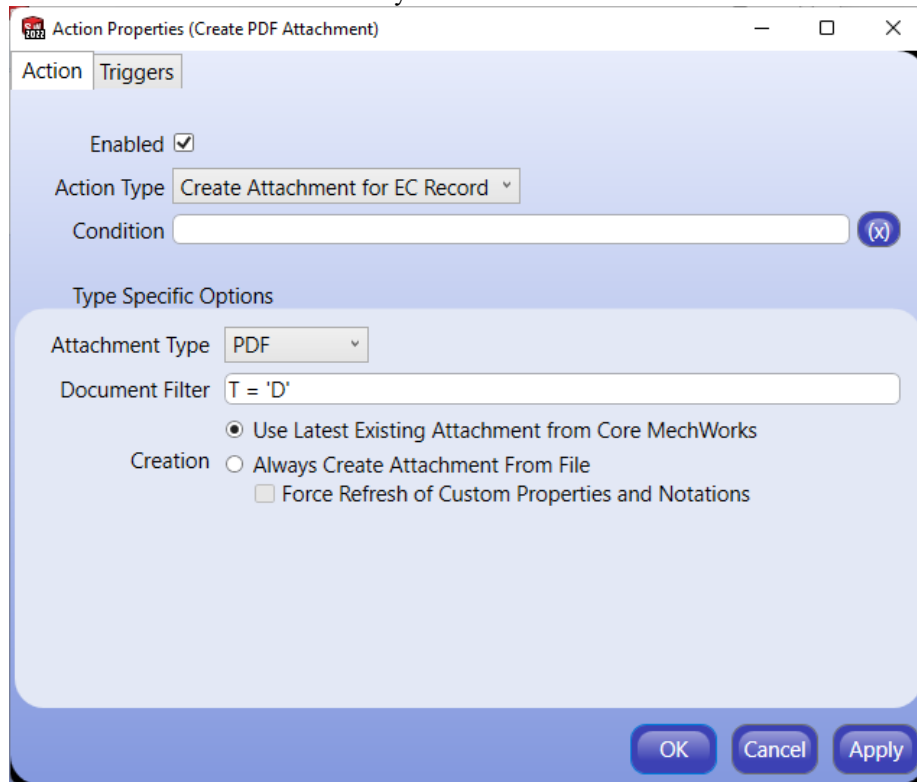

The options for this action are as follows:

Attachment Type: PDF or eDrawing

Document Filter: SQL query to define which documents should generate an attachment

Creation:

Use Latest Existing Attachment from Core MechWorks

The MW Engineering Change tool will first look for a matching attachment in the MechWorks PDM Attachments grid:

Composed of:	Used by:	Preview	Configurations	AllParentProjects	Attachments
T	Description	File_name			
▶	Attachment of document MA-000239	MA-000239.A.PDF			
▶	Attachment of document MA-000239	MA-000239.00.PDF			

In the example above, the MW Engineering Change tool will search the Attachments of each drawing for a PDF attachment. If found, it will create a copy of the most recent PDF file and use it as the attachment for the EC record. If not found, it will open the drawing and save it as a PDF instead.

Always Create Attachment From File

The MW Engineering Change tool will ignore any existing attachments and always open the document and save it as the attachment type (PDF, in this case). This option degrades performance but provides the most up-to-date file.

Force Refresh of Custom Properties and Notations

While the file is open for saving as the attachment type, the MW Engineering Change application will also force a refresh of all custom properties and notation. This further degrades performance but guarantees the most up-to-date information in the attachment.

Global Option

A new option is available to allow administrators to define how attachments should be generated when the user right mouse selects a document and executes the “Create Attachment” command:

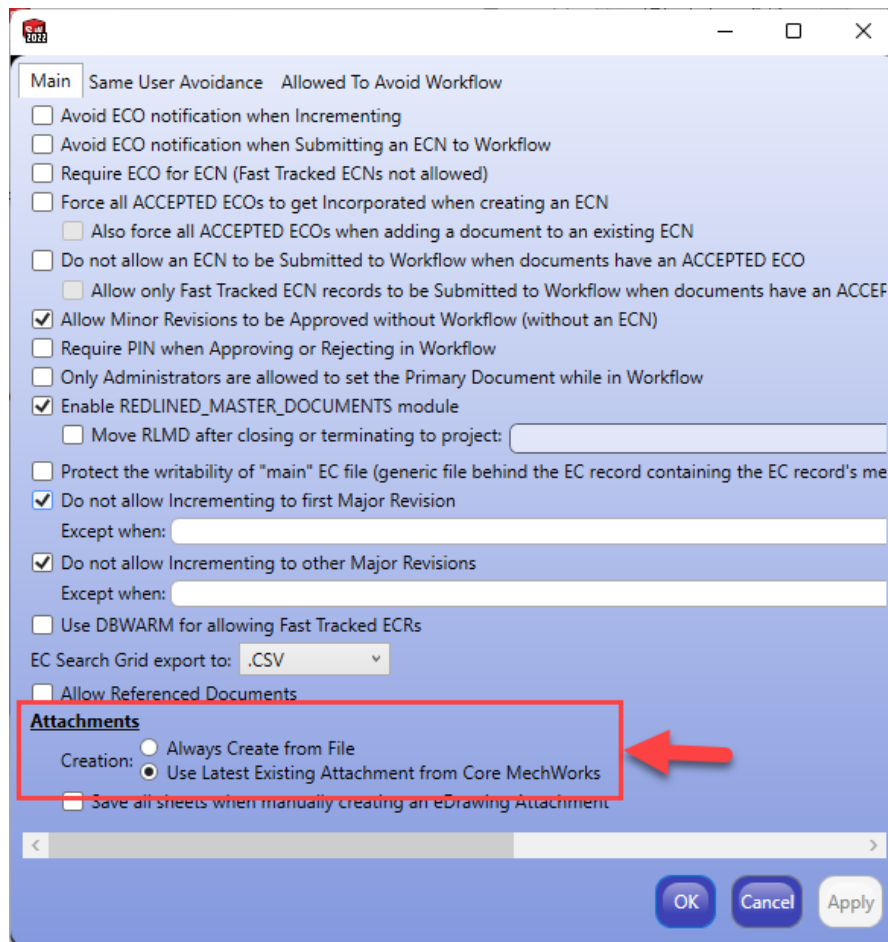
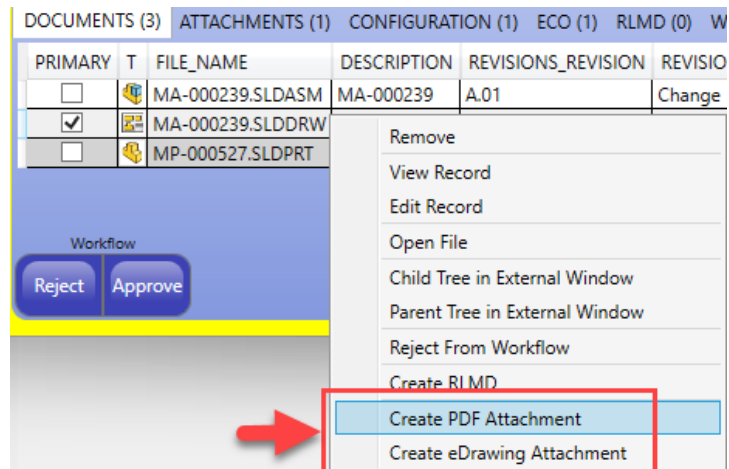



This option is described in more detail on the next page.

Always Create from File

The MW Engineering Change tool will ignore any existing attachments and always open the document and save it as the attachment type (PDF, in this case). This option degrades performance but provides the most up-to-date file.

Use Latest Existing Attachment from Core MechWorks

The MW Engineering Change tool will first look for a matching attachment in the MechWorks PDM Attachments grid:

Composed of:	Used by:	Preview	Configurations	AllParentProjects	Attachments
T Description File_name					
			Attachment of document MA-000239	MA-000239.A.PDF	
			Attachment of document MA-000239	MA-000239.00.PDF	

In the example above, the MW Engineering Change tool will search the Attachments the selected drawing for a PDF attachment. If found, it will create a copy of the most recent PDF file and use it as the attachment for the EC record. If not found, it will open the drawing and save it as a PDF instead.

Database Updates

ABBREV_NAME field

MechWorks PDM now allows for the ABBREV_NAME field in the DBWORKS_USERS table:



USER_ID	FULLNAME	INITIALS	ABBREV_NAME
jdesigner	Joe Designer	JD	Joe D
jmanager	Jane Manager	JM	Jane M

If this field exists in the DBWORKS_USERS table, the MW Engineering Change tool allows for the value in this field to be applied when executing actions, such as applying signatures:

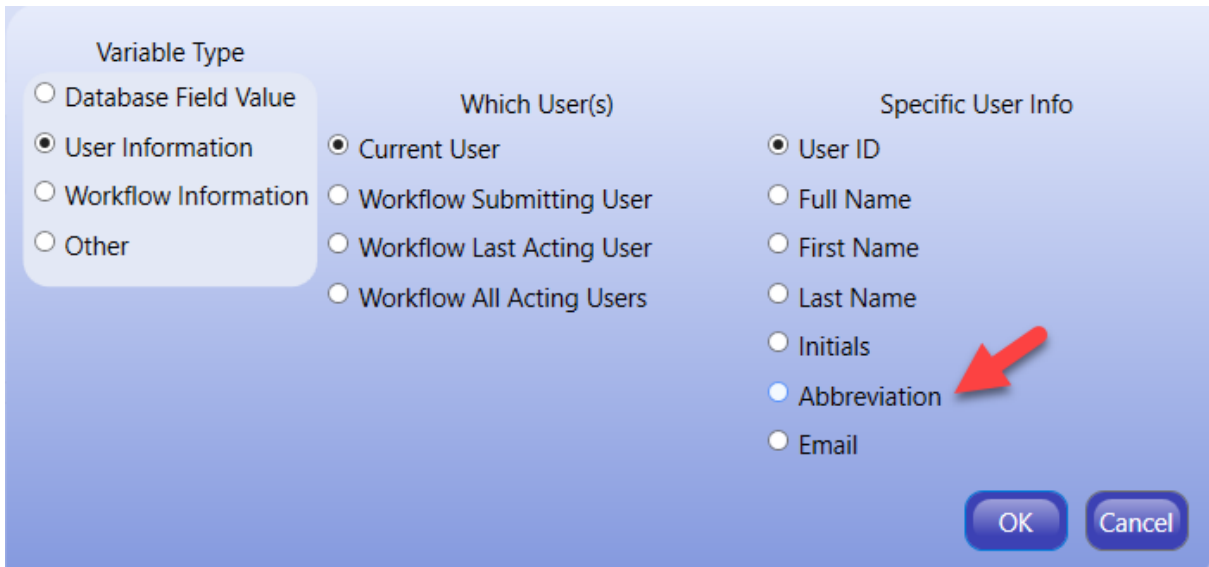

Variable Type

- Database Field Value
- User Information
- Workflow Information
- Other

Which User(s)

- Current User
- Workflow Submitting User
- Workflow Last Acting User
- Workflow All Acting Users

Specific User Info

- User ID
- Full Name
- First Name
- Last Name
- Initials
- Abbreviation
- Email

OK Cancel

Out of the Box User Fields

The out-of-the-box user fields, such as CREATED_BY, will always store the unique USER_ID value in the database

ID	CREATED_BY
ECR-003599	jdesigner

This is because the USER_ID is a unique value used to uniquely identify a user. However, the Data Card Designer tool now allows an Alias to be set for these fields, to allow displaying a different value in the Data Cards:

Field	Type	ReadOnly	Case	Height (in pixels)	Max Length (0=Infinite)	Not Null	Default	Alias
CREATED_BY	Text	EC Controlled	Any	25	0	<input type="checkbox"/>		Abbreviation
CREATION_DATE	DateTime	EC Controlled	Any	25	0	<input type="checkbox"/>		

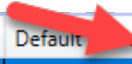
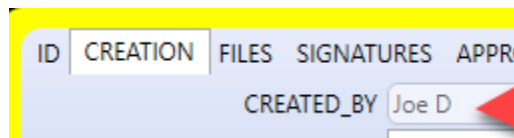
ID CREATION FILES SIGNATURES APPRO

CREATED_BY Joe D

Delete RLMD Tool

Delete RLMD Tool

Administrators now have access to a new tool for deleting Red Lined Master Documents:

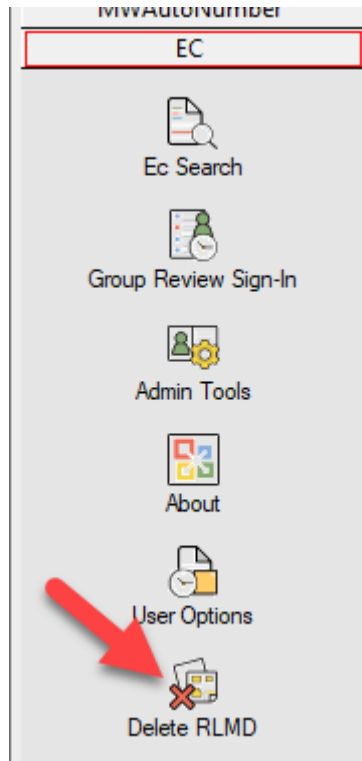

If the administrator selects a Red Lined Master Document and then runs the tool, a confirmation dialog will be presented:

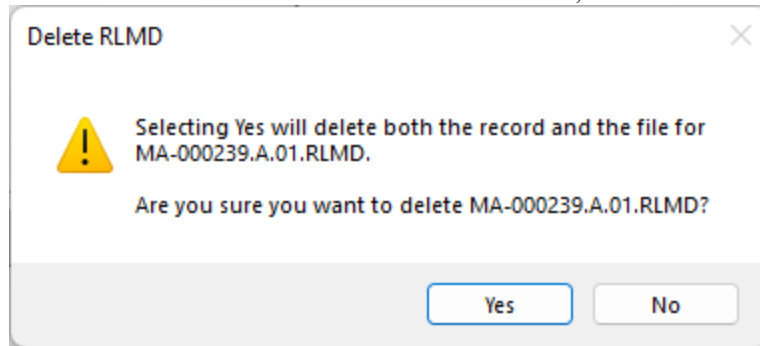

If the administrator selects "Yes", the file for the Red Lined Master Document will be deleted, along with all database records.

Logging Improvements

Logging Improvements

The MW Engineering Change logging will now make sub-folders for each day and each session:

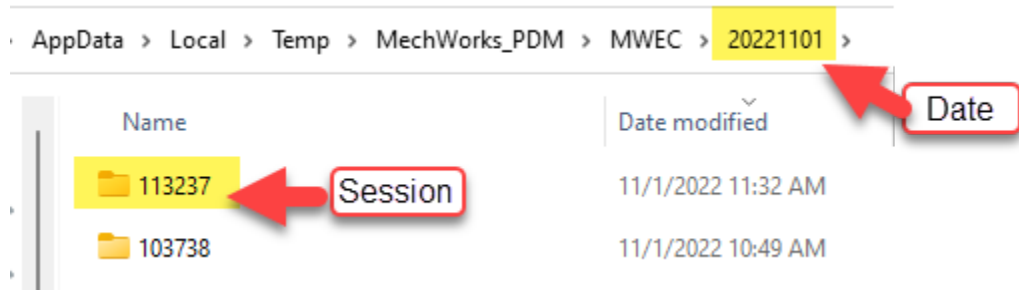

Within each session, several log files are created, each of a different type:

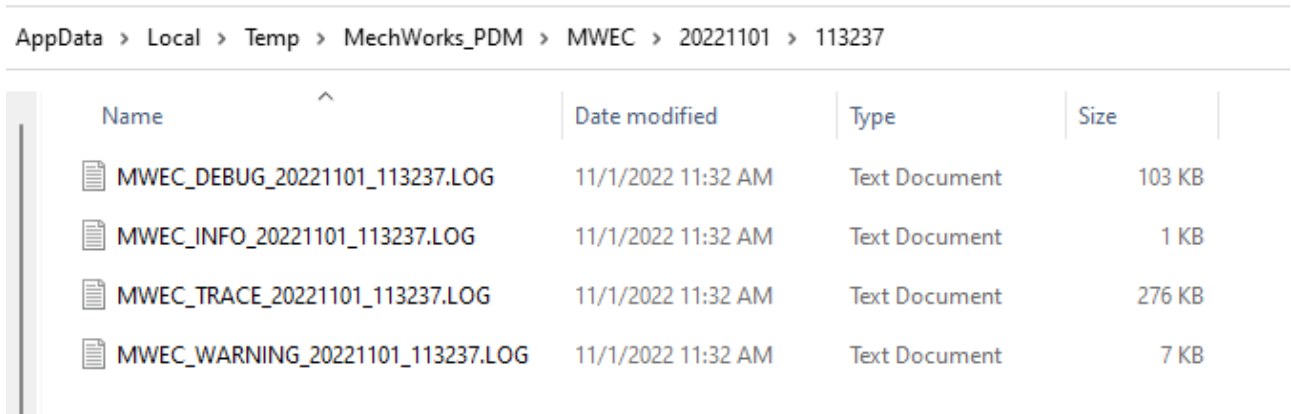

Each type of log is described below:

Fatal: A fatal problem has occurred which will prevent the MW Engineering Change tool from functioning. For example: the main database cannot be reached.

Error: An error has occurred, but it will not prevent the MW Engineering Change tool from functioning. For example: a particular file cannot be found.

Warning: A warning has occurred. For example: an action would normally be fired, except it is not supported in this specific situation. (I.E. An action to create an email would normally attach the EC file. However, the action is getting triggered during an “increment revision” event, which does not inherently include any EC record, so there is nothing to attach.)

Info: General information about an environment is recorded. For example: the DBWARM group of the current user or the version of the currently installed MechWorks PDM application.

Debug: Debugging messages, indicating specific coding information.

Trace: Trace messages, tracking starting and ending specific methods in code.

The trace and debug logs will have a great deal of very detailed information, but it will mostly be useful only to developers. The other four logs will be much smaller but will have information more useful to everyday users.

Edit Revisions Data Card

Edit Revisions Data Card Command

The EC data card now has the ability to access the document's Revisions Data Card directly:

DOCUMENTS (2)		ATTACHMENTS (3)		
PRIMARY	T	FILE_NAME	DESCRIPTION	REVISIONS_REVISION
<input type="checkbox"/>		MA-000239		
<input checked="" type="checkbox"/>		MA-000239		



- View Record
- Edit Record
- Edit Revision Record
- Open File
- Child Tree in External Window
- Parent Tree in External Window

Bug Fixes

- The logs attached to the email created from the About Dialog were sometimes incorrect.
- The user options to activate Trace and Information level logging were not remembered between sessions.
- The WF_ASSIGNED_USER field was updated after the actions fired. This would prevent actions from being able to copy the value into other fields.
- The default rejection email contained the following incompatible variable: <%DOCUMENTGROUP.DOCUMENT.ID+'+WF_REJECT_NOTES.T <> 'D%>
- The MwPdmApi.dll file was not always referenced in the proper location.
- The OnShowPreviewLabel.PAR file was not always properly installed.
- Actions would not allow copying from a default DBW_EC field into another field
- Changing the order for one EC type would often also change to order for another EC type (on create ECR vs on create ECN).
- 4.00.11: The “Idle in Workflow” search was incorrectly returning records recently submitted to workflow